

Instructions for use: Sparkplug extension lead

Introduction

These leads are designed to aid diagnostics on secondary ignition circuits by allowing an HT measurement to be made when there are no, or limited access, to any plug leads. The leads are specifically designed for use with an HT pick-up as part of an oscilloscope diagnostic kit.

Please read and follow these instructions, failing to comply with these user notes could result in expensive electrical components being damaged.

The suppliers of this product take no responsibility for any damaged caused whilst testing circuits. Secondary ignition circuits can produce in excess of 40Kv and extreme care should be taken. If the lead becomes damaged in any way it should be discarded and replaced.

Pencil coils (coil-per-cylinder)

These coils are very popular on modern vehicles and either push fit directly over the sparkplug, or are retained by a securing bolt. These coils can be tested individually, or if a complete set of extension leads is available then all cylinders can be tested together.

1. With the ignition turned off disconnect the coil from the sparkplug. This will inevitably require the multi-plug to be disconnected and reconnected. To aid this operation it may be worth spraying the plug with some release oil to prevent any damage to the release tabs.
2. Once the coil is disconnected from the sparkplug and has its multi-plug refitted, place the extension lead between the sparkplug and the coil. Ensure there is a positive 'click' into place at both ends. If for any reason there is not a secure fit then the test lead should not be used.
3. Ensure that any leads or the coil are not resting on any components that will get hot or rotate.
4. If the coil was secured to the engine via a retaining bolt then fit the 'safety earth' lead to the coil using the bolt supplied and back to the cylinder head. Again if for any reason this is not possible the test procedure should be terminated. Note: some coils have protective grease on them which prevents the lead making a secure connection, it is advisable to wipe this off and reapply after use.
5. If multiple cylinders are to be tested at the same time then follow instructions one to four for the remaining cylinders.
6. Double check all connections before attempting to start the vehicle's engine.
7. Connect the HT pick-up from the oscilloscope kit to the extension lead and select: Automotive→Ignition→Secondary→Secondary CPC (negative fired), from the drop down menu of the software.

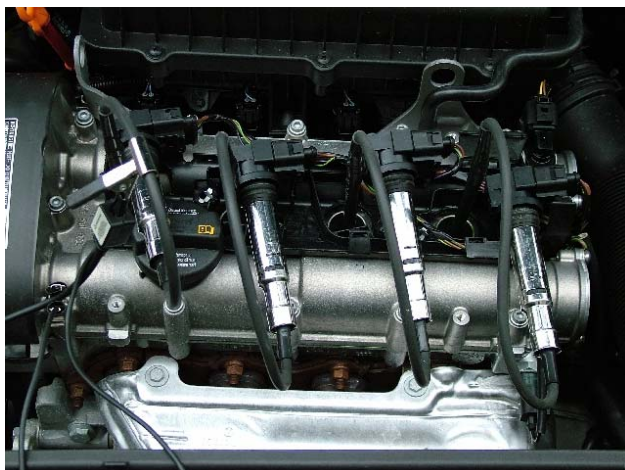
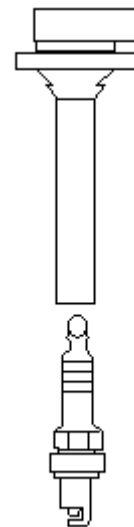

Cartridge coils

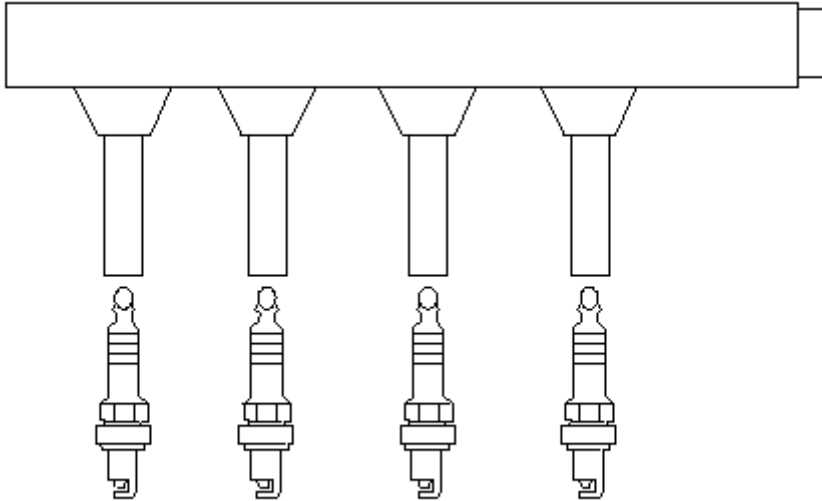

This system can only be tested if the user has the same number of extension leads as coils within the cartridge coil-pack. The cartridge coil-pack is fitted directly over all the sparkplugs and lifts off in one unit.

1. With the ignition turned off disconnect the coil-pack from the sparkplugs. This will inevitably require the multi-plug to be disconnected and reconnected. To aid this operation it may be worth spraying the plug with some release oil to prevent any damage to the release tabs.
2. Once the coil-pack is disconnected from the sparkplugs and has its multi-plug refitted, place an extension lead between each of the sparkplugs and the coils. Ensure there is a positive 'click' into place at both ends and the correct lead goes to the corresponding plug and coil. If for any reason there is not a secure fit then the test lead should not be used.
3. Ensure that any leads or the coil-pack is not resting on any components that will get hot or rotate.
4. If the coil-pack was secured to the engine via a retaining bolt then fit the 'safety earth' lead to the coil-pack using the bolt supplied and back to the cylinder head. Again if for any reason this is not possible the test procedure should be terminated.
5. Double check all connections before attempting to start the vehicle's engine.
6. Connect the HT pick-up from the oscilloscope kit to one of the extension leads and select: Automotive→Ignition→Secondary→Secondary CPC (negative fired), from the drop down menu of the software. Note: it may be possible that the coil-pack is in fact wasted spark and then on a four cylinder engine two of the plugs will fire positive and require the (positive fired) selection from the automotive menu.



Wasted-spark coil-pack over one sparkplug

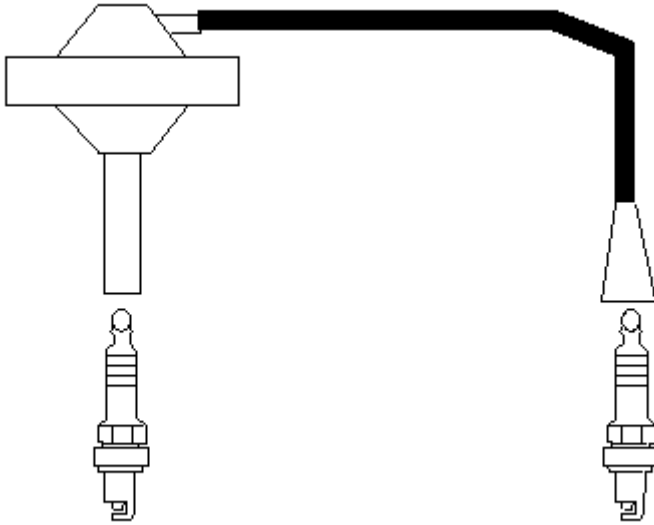

This system has a wasted-spark coil pack mounted directly over one cylinder, whilst a plug lead connects the other end of the double-ended coil to another sparkplug. In the case of the Alfa Romeo twin-spark system the second sparkplug is within the cylinder head for the same cylinder. Other systems may use a pair of these coils on a four cylinder engine and it may be possible see two of the HT plug leads. As systems vary the user will have to decide on the most appropriate connection method.

1. With the ignition turned off disconnect the coil from the sparkplug. This will inevitably require the multi-plug to be disconnected and reconnected. To aid this operation it may be worth spraying the plug with some release oil to prevent any damage to the release tabs.
2. Once the coil is disconnected from the sparkplug and has its multi-plug refitted, place the extension lead between the sparkplug and the coil. Ensure there is a positive 'click' into place at both ends. If for any reason there is not a secure fit then the test lead should not be used.
3. If the existing plug lead is not long enough to allow the coil to be disconnected and laid on top of the cylinder head then a second extension lead will be required.
4. Ensure that any leads or the coil are not resting on any components that will get hot or rotate.
5. If the coil was secured to the engine via a retaining bolt then fit the 'safety earth' lead to the coil using the bolt supplied and back to the cylinder head. Again if for any reason this is not possible the test procedure should be terminated.
6. If multiple cylinders are to be tested at the same time then follow instructions one to five for the remaining cylinders.
7. Double check all connections before attempting to start the vehicle's engine.
8. Connect the HT pick-up from the oscilloscope kit to the extension lead and select: Automotive→Ignition→Secondary→Secondary DIS (negative fired) or DIS (positive fired) from the drop down menu of the software. This will depend on which of the two leads of the coil is tested as one will fire negative and one positive.